

DVC SEPEC

Industrial UPS from 200 to 1200 KVA

Description

The DVC SEPEC range of industrial UPS is an innovative system to reduce the effect of electrical disturbances on industrial processes, eliminating brief interruptions and transitory overvoltages for the most critical industrial processes.



Its main function is to guarantee the continuity of the power supply in industrial processes where maximum loads availability of mains is a fundamental requirement. Its design allows it to work together with emergency generator units in a configuration that eliminates network interruptions completely, avoiding interruptions, also eliminating generator declassification problems deriving from harmonic generation of double conversion UPS.



Industrial UPS DVC SEPEC 800 KVA

> Option EQL:

The EQL, Load Equaliser, allows this to be hybridised with an emergency generator unit and guarantee the continuous operation of the unit in the case of short-duration interruptions (up to 5 minutes with the SEPEC only) and long duration (SEPEC + Emergency generator unit).

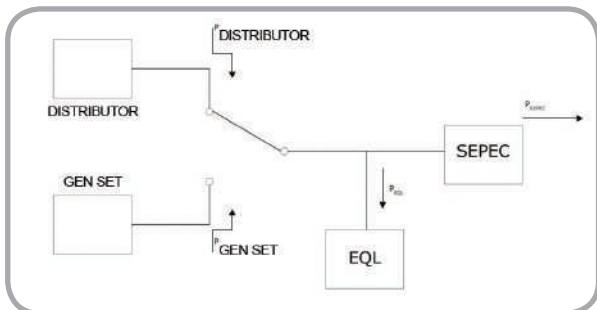

Features

- > High-efficiency emergency supply system > 99%
- > From 200 KVA to 1200 KVA
- > Compatible with already installed protection systems
- > Minimum investment required and reduction of operating costs
- > Maximum system robustness
- > Can be integrated with existing supply guarantee systems available: all emergency generator units, etc.
- > Records disturbances (day, hour, duration)
- > Greater reliability, MTBF and life expectation
- > Voltage impulse elimination system (optional)
- > DSP digital control system
- > Avoid mains interruptions even when returning from Emergency Generator Unit
- > Turnkey project: design tailor-made design for special needs
- > Does not introduce harmonics into the installation (upstream)
- > Does not expose services to inverter distortions
- > Safety and reliability
- > Low energy consumption (no need air-conditioning for conversion system)
- > TVSS system: maintenance free electronic surge arrester (optional)
- > Advanced management system, battery verification and diagnostics (optional)
- > Capable of operating with regenerative loads (Breaker optional)
- > Air-conditioned battery cabinet (optional)

telecommunications

railway

industrial

logistics centres

production processes

robots



GENERAL SPECIFICATIONS					
Model	DVC SEPEC 200	DVC SEPEC 400	DVC SEPEC 600	DVC SEPEC 800	DVC SEPEC 1200
Power KVA	200	400	600	800	1200
Total efficiency	> 99% in any load condition				
Overload	120% permanent				
INPUT					
Voltage range	340 - 440 Vac (in bypass) ⁽¹⁾				
Frecuency admisible	50/60 Hz ± 10%				
Harmonic distortion	Does not introduce harmonic distortion				
OUTPUT					
Voltage	340 - 440 Vac (in bypass) ⁽¹⁾				
Frecuency	50/60 Hz programmable				
Type of wave	Pure sinewave				
Active redundancy in inverter	Parallel inverters				
Crest factor	3:1				
Harmonic distortion of output voltage	<1.5% (THD)				
Power KVA/KW	200/200	400/400	600/600	800/800	1200/1200
BATTERIES ⁽²⁾					
Battery type (Ah)	Sealed lead acid VRLA				
Estimated service life	10 years				
Air-conditioning for battery cabinet	Optional				
Battery current ripple	0 Amps in permanent regime				
Autonomy	5 min at full power - PFC 0,8 (other backup times under demand)				
PROTECTIONS					
Voltage impulses	Yes (non degradable) operation threshold Unx.1 > 900 Jules				
Against short-circuit	Yes (permanent)				
Current limitation	Yes				
Overload	Yes				
Manual and static bypass	Yes				
Maintenance bypass	Yes (without supply interruption)				
RFI filter	Yes				
Battery charger protection	Yes				
Battery temperature compensation	Yes				
COMUNICATIONS					
Local and remote	TCP/IP, MÓDEM RTC ó GSM/GPRS				
STANDARDS					
Certifications	CE				
Directives	73/23/CEE-93/68/CEE				
OTHERS					
Permitted relative humidity	0-85% (excluding battery)				
Altitude without power reduction	2000 m.s.n.m.				
Operation temperature	0-45°C				
Dimensions UPS ⁽²⁾ WxHxD (mm)	1210x640x2445	1620x640x2445	2435x640x2445	2435x640x2445	4870x640x2445
UPS Weight	650	950	1345	1575	2x1345+300

⁽¹⁾ For other voltages please consult us.

⁽²⁾ External battery cabinet, consult weights and dimensions for different power size.

Specifications may be changed without notice